

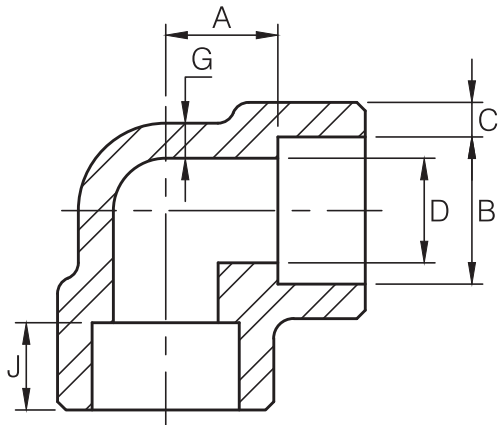

# 90° ELBOW

ASME B16.11-2016(Revision of ASME B16.11-2011)



Dimensions are in millimeters.

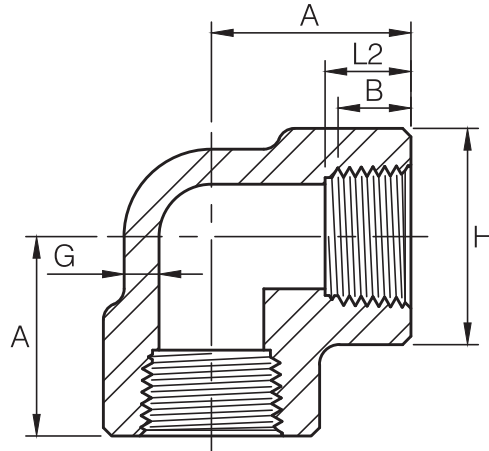

Dimensions are in millimeters.

Socket Welding								
DN	Nom. Pipe Size	B <sup>(2)</sup>	C <sup>(1)</sup>		D <sup>(2)</sup>	A <sup>(2)</sup>	G (Min)	J (Min)
			(Avg)	(Min)				

3000Lb								
6	1/8	10.8	3.18	3.18	6.9	11.0	2.41	9.5
8	1/4	14.2	3.78	3.30	9.3	11.0	3.02	9.5
10	3/8	17.6	4.01	3.50	12.6	13.5	3.20	9.5
15	1/2	21.8	4.67	4.09	15.8	15.5	3.73	9.5
20	3/4	27.2	4.90	4.27	21.0	19.0	3.91	12.5
25	1	33.9	5.69	4.98	26.7	22.5	4.55	12.5
32	1-1/4	42.7	6.07	5.28	35.1	27.0	4.85	12.5
40	1-1/2	48.8	6.35	5.54	40.9	32.0	5.08	12.5
50	2	61.2	6.93	6.04	52.5	38.0	5.54	16.0
65	2-1/2	73.9	8.76	7.67	62.7	41.0	7.01	16.0
80	3	89.8	9.52	8.30	78.0	57.0	7.62	16.0
100	4	115.2	10.69	9.35	102.3	66.5	8.56	19.0

6000Lb								
6	1/8	10.8	3.96	3.43	4.0	11.0	3.15	9.5
8	1/4	14.2	4.60	4.01	6.4	13.5	3.68	9.5
10	3/8	17.6	5.03	4.37	9.2	15.5	4.01	9.5
15	1/2	21.8	5.97	5.18	11.8	19.0	4.78	9.5
20	3/4	27.2	6.96	6.04	15.6	22.5	5.56	12.5
25	1	33.9	7.92	6.93	20.7	27.0	6.35	12.5
32	1-1/4	42.7	7.92	6.93	29.5	32.0	6.35	12.5
40	1-1/2	48.8	8.92	7.80	34.0	38.0	7.14	12.5
50	2	61.2	10.92	9.50	42.9	41.0	8.74	16.0

9000Lb								
15	1/2	21.8	9.35	8.18	6.4	25.5	7.47	9.5
20	3/4	27.2	9.78	8.56	11.1	28.5	7.82	12.5
25	1	33.9	11.38	9.96	15.2	32.0	9.09	12.5
32	1-1/4	42.7	12.14	10.62	22.8	35.0	9.70	12.5
40	1-1/2	48.8	12.70	11.12	28.0	38.0	10.15	12.5
50	2	61.2	13.84	12.12	38.2	54.0	11.07	16.0

Threaded						
DN	Nom. Pipe Size	Length of Thread. (Min)		A	G (Min)	H
		B <sup>(*)</sup>	L2 <sup>(*)</sup>			

2000Lb						
6	1/8	6.4	6.7	21	3.18	22
8	1/4	8.1	10.2	21	3.18	22
10	3/8	9.1	10.4	25	3.18	25
15	1/2	10.9	13.6	28	3.18	33
20	3/4	12.7	13.9	33	3.18	38
25	1	14.7	17.3	38	3.68	46
32	1-1/4	17.0	18.0	44	3.89	56
40	1-1/2	17.8	18.4	51	4.01	62
50	2	19.0	19.2	60	4.27	75
65	2-1/2	23.6	28.9	76	5.61	92
80	3	25.9	30.5	86	5.99	109
100	4	27.7	33.0	106	6.55	146

3000Lb						
6	1/8	6.4	6.7	21	3.18	22
8	1/4	8.1	10.2	25	3.30	25
10	3/8	9.1	10.4	28	3.51	33
15	1/2	10.9	13.6	33	4.09	38
20	3/4	12.7	13.9	38	4.32	46
25	1	14.7	17.3	44	4.98	56
32	1-1/4	17.0	18.0	51	5.28	62
40	1-1/2	17.8	18.4	60	5.56	75
50	2	19.0	19.2	64	7.14	84
65	2-1/2	23.6	28.9	83	7.65	102
80	3	25.9	30.5	95	8.84	121
100	4	27.7	33.0	114	11.18	152

6000Lb						
6	1/8	6.4	6.7	25	6.35	25
8	1/4	8.1	10.2	28	6.60	33
10	3/8	9.1	10.4	33	6.98	38
15	1/2	10.9	13.6	38	8.15	46
20	3/4	12.7	13.9	44	8.53	56
25	1	14.7	17.3	51	9.93	62
32	1-1/4	17.0	18.0	60	10.59	75
40	1-1/2	17.8	18.4	64	11.07	84
50	2	19.0	19.2	83	12.09	102
65	2-1/2	23.6	28.9	95	15.29	121
80	3	25.9	30.5	106	16.64	146
100	4	27.7	33.0	114	18.67	152

(1) Average of socket Wall Thickness around periphery shall be no less than listed values. The minimum values are permitted in localized areas.

(2) Tolerance see page 21.

(\*) Dimension B is minimum length of perfect thread. The length of useful thread (B plus threads with fully formed roots and flat crests) shall not be less than L2 (effective length of external thread) required by American National Standard for pipe threads (ANSI / ASME B1.20.1).